

MINE WATER. GRANADA, SPAIN. 1985.

**THE ORIGIN AND PROCESS
CONTROL OF WET ROCK
MATERIAL INRUSHES**

Zsolt KESSERÜ
Central Institute for Mining Development
H-1037 Budapest, Mikoviny u.2-4.
HUNGARY

ABSTRACT

Under given stress conditions fissured or broken clay or marl penetrated by water may cause a sudden rock movements/ inflows. These dangerous rock water interaction phenomena are called wet rock material inrushes. The paper presents observations experiences, laboratory tests and the mechanical model of the phenomena. The methodology of predicting, the selection of proper control measures and brief case studies are also discussed.

1. PROBLEM PRESENTATION

Under conditions of wet semi-permeable rocks /clays, marls/ surrounding the mine openings, sudden rock movements occurred in many mines. In those cases only, which have been studied by the author, 14 men died due to wet rock material inrush accidents during the last ten years. These serious cases require deeper study of the phenomena for the sake of more effective control measurements.

The paper presents

- experiences, observations on wet rock material movement phenomena,
- a simplified mechanical model of the phenomena based on experiences/observations/experiments,
- methodology of forecasting the hazard of wet rock material inrushes,
- selection of the possible/reasonable ways of control,
- brief case histories from the authors consulting practice /in homeland and abroad/.

2. EXPERIENCES, OBSERVATIONS ON WET ROCK MATERIAL INRUSHES/MOVEMENTS

2.1. Terminology

Broken rock /clay, marl/ pieces of wet surface with relatively small water content /solid/fluid ratio 10/1 or less/ are called "wet rock material". Under open conditions, /e.g. laying in the floor of the mining opening/ this system of broken wet rock pieces are often forming relatively inclined /15-30°/ slopes.

According to the terminology of this paper loosen granular grounds, like gravels, sands, slimes are not regarded as "wet rock materials".

2.2. The wet rock material inrush phenomena

Typical stages of the phenomena are as follows:

- Phenomena of increased rock pressure were observed first.
- Sudden inrush/movement of broken and wet clay, marl pieces started with a relatively small inflow of water. The volume of the inrushed rock material varied between 5-500 m³.
- In some cases only slow 1-2 m/day movement of the rock walls of the opening were observed.
- The moving rock mass looks like a "fluid of high viscosity" although the rock mass consists of broken wet rock pieces.
- When the process stopped the mass of wet rock pieces were forming slopes of 15-25°.
- When the rock movement stopped no rock stress phenomena were observed.

Some typical features can also be pointed out.

- The inrushes often occurred in wet area during repeated undermining of clay-marly layers. During slicing of the seam /e.g. coal seam/ this phenomenon never occurred in the first slice, but in the second, third, fourth slices. If earlier wet rock material inrushes, or conventional water inrushes had occurred in the overlying slice, then later wet rock material inrushes often occurred in the underlying slices.
- These phenomena occur only under those rock conditions when the rock material consists of clay and marls. Hard rocks never produce such phenomena.
- In some cases high pressure reservoir layers were in the vicinity, but in many other cases depressurized water reservoir conditions were observed.

3. PROCESS MODELING

The presence of water, the rock stress phenomena, the relatively soft properties of rocks are showing a dangerous equilibrium state of a semi-permeable penetrated rock system.

The process of forming the dangerous mechanical state of rock equilibrium is discussed step by step /See Fig.1./.

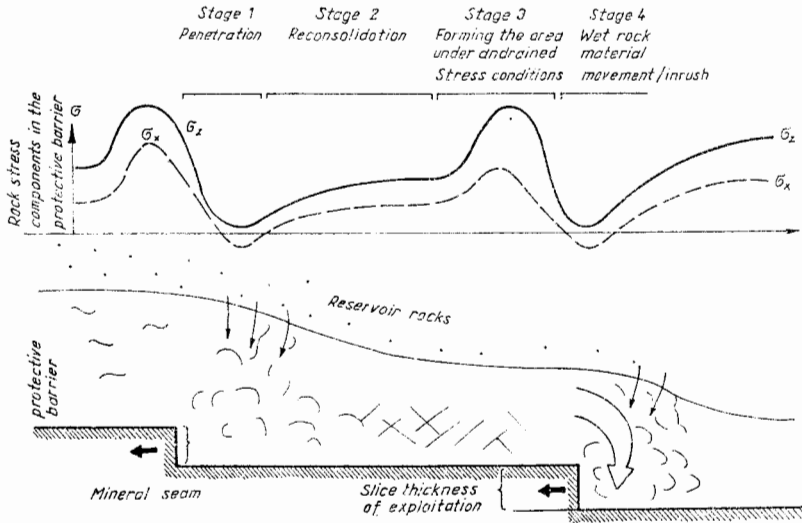

Fig. 1 Stages of process forming

- The first stage is the penetration of the fissures of /soft/ rock or a broken /soft/ rock zone.

- The second stage is the compression, reconsolidation of wet fissured/broken soft rock. The compression forms a rock mass of low permeability with a "secondary" water content. /The primary water content is in the primary pores of the clay and marl, the "secondary" water is in the fissures.

In case of compressing broken soft rock material, so called "clay breccia" will be formed.

- The third stage is a relatively sudden increase of rock pressure /e.g. due to a quick approach of a new mine opening/. Because of the low permeability of the compressed fissured/broken material, the water in the closed fissure cannot filter quickly from the fissures, consequently the water pressure increases. It means, that a part of the increased pressure is held by the water. This is called as "undrained pressure" and consequently the rock material loses most of its "inner friction". It operates as a closed fluid in the surrounding rock. This kind of unstable rock conditions are well known in geotechnical engineering practice. /Kézdi 1972/. During this stage increased rock pressure phenomena can be detected at the mine opening as a signal of danger.

The last stage is the wet rock material movement due to the unstable state of mechanical equilibrium, which movement causes a new stable equilibrium state.

If the unstable area is closed into a rock mass, the mine opening approaching quickly provokes a sudden wet rock material inflow.

4. LABORATORY TESTS

The process presented above was detected experimentally also by two different laboratory tests.

Fig. 2/a presents a special triaxial filter cell. Cylindrical clay samples fissurized artificially were tested under different rock pressure and water pressure/seepage conditions. /Kesserü 1976/ The observations/measurements at one of the tests are presented in Fig. 2/b marking the three stages mentioned before. Although different rock stress components were operating during the third stage, because of the lowered "inner friction" of the rock sample, the movements of the rock sample equalized the stress components. It means, that under the given stress condition the rock sample operated as a fluid of high viscosity.

Fig. 2 Triaxial filter cell and tests results

a. Test equipment

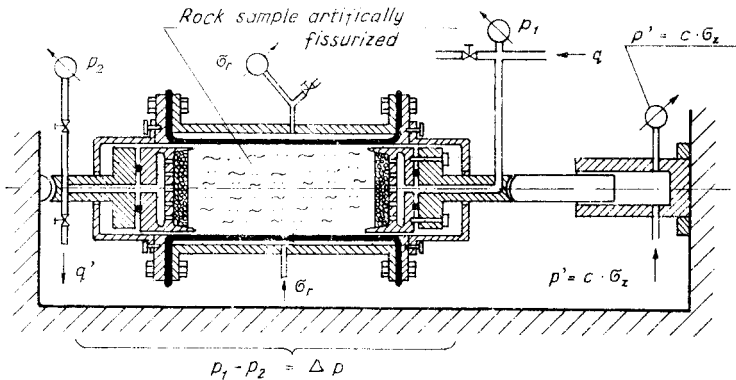

b. Results of test of soft sample

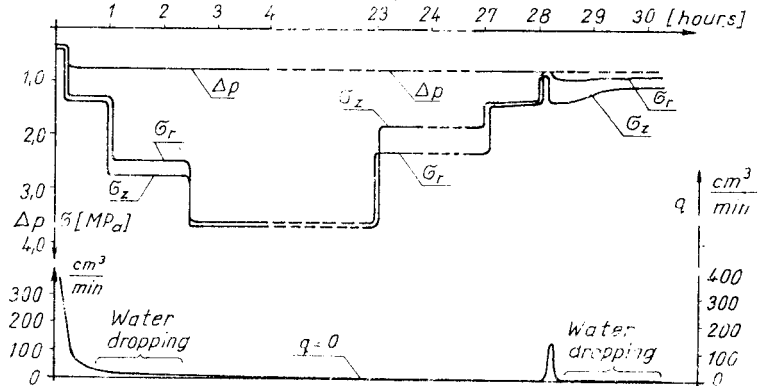

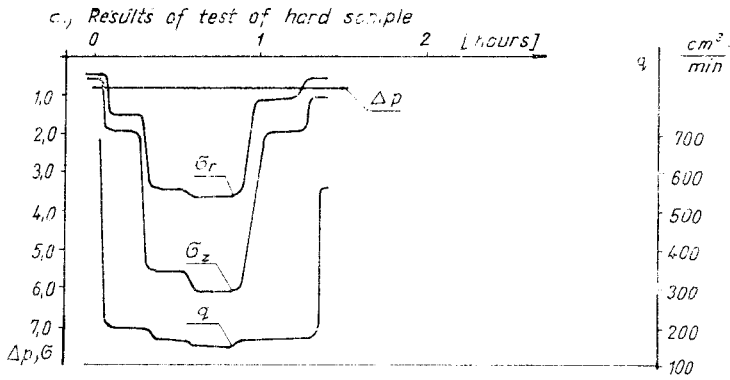

Fig. 2 Triaxial filter cell and test results

Fig. 2/c shows such a case, when the harder rock sample preserved its water conductivity. Consequently unstable equilibrium state was not formed in this case.

The same phenomena were detected during the compression of broken material according to the Fig.3. /Kesserü 1976/b/. The large but very simple compression cell is presented in Fig.3/a. This cell was filled with broken rock material /from the undermined area/ and with water. During compression the

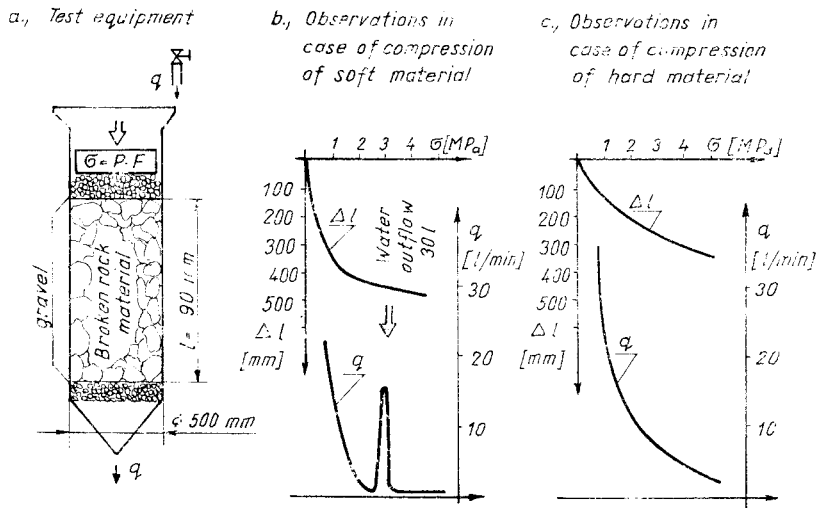

Fig. 3 Reconsolidation tests for broken material

real stress conditions were not indicated by this simple testing equipment, but the different stages were detected by the rate of water outflow. /e.g. the stop of water outflow indicated stage two, the material outflow indicated the "last" stage./ These stages are marked in the observation curves /Fig.3/b/. The word "last" must be marked with inverted commas, because the inrush as a material extraction modified the equilibrium conditions even during continued compression. The results of laboratory tests point out, that only proper relations between the stress conditions and the rock properties cause dangerous state of equilibrium for wet rock material movements.

5. FORECASTING THE HAZARD OF WET ROCK MATERIAL MOVEMENTS

Four main interacting factors should be studied simultaneously

- the possibility of penetration
- the rock properties
- the stress conditions
- the location of mine openings relating to the dangerous zones.

The hazard of water penetration can be determined by studying the reservoirs and the natural protective barriers/ layers locating between the reservoir and the planned or existing openings. The effect of the openings /e.g. the undermining/ should also be taken into account. /Kesserü 1976 a,b, 1978, 1982, Whittaker-Shing 1979, Whittaker-Aston 1982/.

The rock properties should be studied by conducting conventional laboratory tests with special regard to rock water interactions and by applying special test equipments as presented in Chapter 4. The "in situ" rock conditions should also be tested by coring undisturbed samples. The zones impacted by mine openings /e.g. undermined zones/ can also be sampled by special coring. /Kassai 1976/

Stress conditions should be studied first by in situ measurements /Kesserü 1976/a, 1982, 1984, Whittaker-Shing 1979, Whittaker-Aston 1982/. Under conditions of soft rocks hydrofracturing tests can provide directly the most important stress component for evaluating the protective barriers /Kesserü 1984/. Equivalent material model studies provide visible informations on forming broken and fissured zones around the openings. Finite element stress analyses fitted to the natural conditions applying "in situ" measuring data have been used successfully. /Kesserü 1976/b, Kesserü-Havasy-Schmieder 1978/

In the course of finite element stress analyses varieties of mine opening locations of mining methods can be investigated and compared. /Roller-Cserhalmi 1976/

The proposed methodology was successfully used in some practical cases /Kesserü 1976, 1978, Kesserü-Havasy-Schmieder 1978/ for forecasting the hazard of wet rock material movements and for selecting the proper control measures as well.

6. SELECTION OF CONTROL MEASURES

The main ways of control are as follows:

- Protection against penetration
- Control of stress conditions
- Barriers between the zones of dangerous equilibrium and the mining operations.

These main ways can also be combined. E.g. the width of barriers will also modify the stress conditions.

6.1. Protection against penetration

Under given reservoir location and protective barrier/layer conditions the effect of depressurizing the reservoir and varieties of mining methods should be analysed interactively, and simultaneously comparing the water pressure and the rock pressure conditions in the protective barrier /Kesserü 1984/ using the methodology discussed in Chapter 5. Without effective protecting barrier the drainage of the reservoir cannot mostly provide the required effect, because the remained water content of the reservoir /e.g. capillar-water/ can also penetrate the fissures of clay.

If reasonable solution for protecting against penetration cannot be realized, other ways of control should be considered.

6.2. Modification of stress conditions

The existing and the potentially penetrated zones should be predicted first by investigations discussed in sub-chapter 6.1. Zones of former water inflows, wet rock material inrushes should be considered as zones of existing danger. Possibilities of water accumulations at the boundary of the water reservoir and the protective barrier/layer and at the floor of the abandoned area should be carefully considered. The potentially penetrated /wet/ zones can be checked by pilot holes /by coring and/or by geophysical logging/.

Having determined the penetrated zones, the penetrated rock properties have to be determined /as discussed in Chapter 4/. For reasonable varieties of mining methods stress analyses should be carried on according to Chapter 4.

If the thickness of mineral seam is less than 15-20 m, sub-level caving of the total seam may provide better solution, instead of slicing, because the penetration often starts at the abandoned zone only as a consequence of which in the course of the exploitation of the next slice penetrated /wet/ zones would be undermined. /See Fig.1./ In case of sublevel caving the undermining of penetrated zones will never occur. In this case lateral barrier pillars and/or the proper layout and time sequence of /longwall/ faces should be carefully considered/analysed.

6.3. Barrier pillars

Application of barrier rock pillars locating between the penetrated zones under dangerous equilibrium state and mining operations are the only effective measures against wet rock material movements from zones of existing danger. The distance and the width of the pillar may also modify the stress conditions at the penetrated zone.

When sizing the barrier pillar the stability of the pillar rock mass should be studied first using well known methods of mechanical analyses. /Kesserü 1982, 1984/

The protective effect of the barrier against hydrofracturing caused by the wet rock material /as a fracturing liquid/ should be checked next. /Kesserü 1984/

On the site measurements should be carried out for the purpose of reliable sizing. In those cases, when proper data are not available, oversized pillars have to be used first. Under protection of the oversized pillar, the necessary "in situ" measurements can be carried on without any hazard.

7. BRIEF CASE HISTORIES

Simplified case histories derived from particularly practical cases are presented in this Chapter.

Case A The geological and mining conditions are shown schematically by cross section in Fig.4. The brown coal seam /thickness of 80-100 m/ was exploited in horizontal slices by sublevel caving. The slice thickness varied between 6 and 16 m.

Although the overlying water bearing sand had been effectively depressurized, wet rock material inrushes occurred at those area, where the thickness of the clay was less than 45-50 m in the second, third or in the fourth slices. Most of the wet rock material inflows occurred at night indicating some differences between the actual thickness volume of coal tapping in day-time and at night.

Having determined the origin of the inrushes /see Fig.1/ the necessary protective barrier thickness was determined for different mining methods. /The methods discussed in Chapter 5. were used practically at first for that practical case which served as background for "case A". As a result of the application of methods presented in Chapter 5. three areas were determined. /See Fig. 4./ In the first area sublevel caving was allowed /taking into account all uncertainties of tapping the coal even at night/. In the second area only normal caving of a slice thickness less than 3,6 m was allowed. /In case of normal caving there is no uncertainty with regard to the actual thickness of the exploitation/.

The variety of backfilling was excluded for many technical/ economical reasons and consequently in the third area a proper coal protective barrier served for safety of the normal caving. For all the above listed cases maximum depressurization of the sandy layers was proposed and designed. Presently the exploitation of areas 1 and 2 are just being completed

without any accidents.
 Depressurization in area 3 is being carried out.

Case B The geological and mining conditions are shown schematically in Fig.5. The inclined, tectonically disturbed brown coal seam was exploited by applying horizontal slices /6-15 m/ using mostly sublevel caving methods. Heavy water inrushes occurred first from the overlying limestone reservoir. Although the dewatering of the limestone reservoir had been successfully completed, water inflows, water inflows combined with wet rock material and wet rock material inrushes without significant water inflows occurred. All wet rock material in-

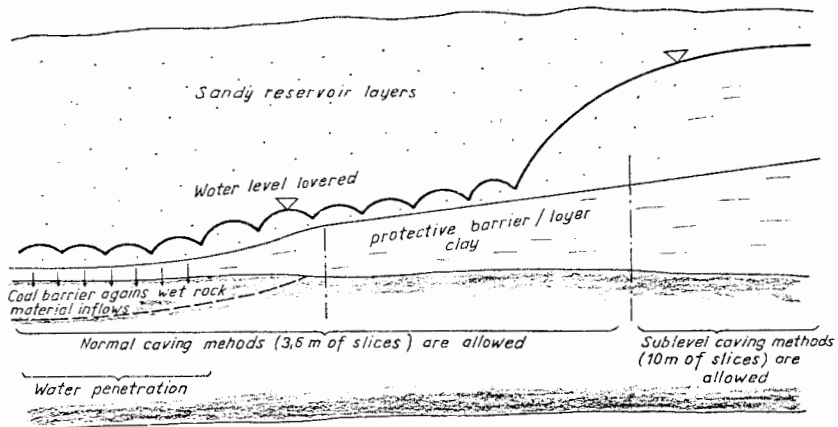

Fig. 4 Schematic geological section for case "A" and zones for different mining methods and protective measures

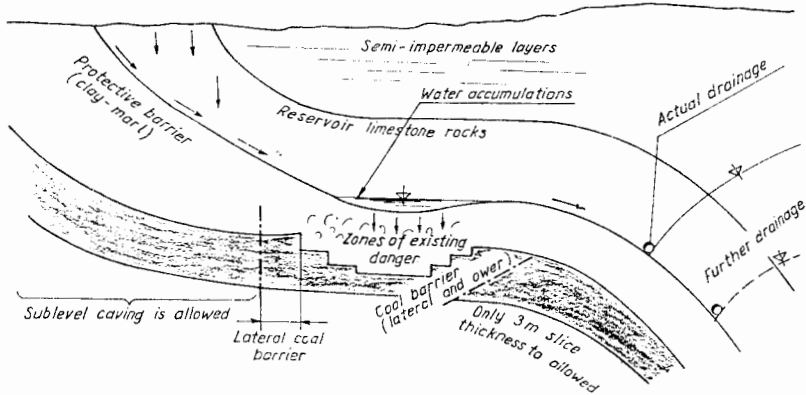
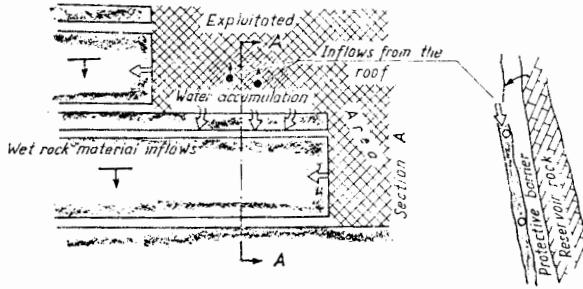

Fig. 5 Schematic cross section for case "B" and the protective measures

a, Problem presentation



b, Protection measures

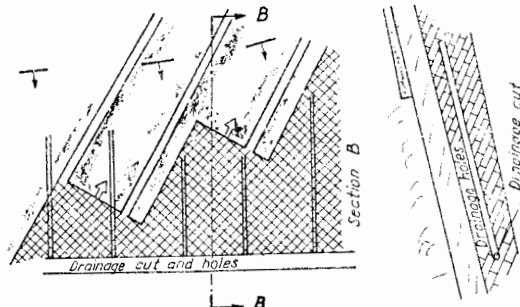

Fig. 6 Case „C“

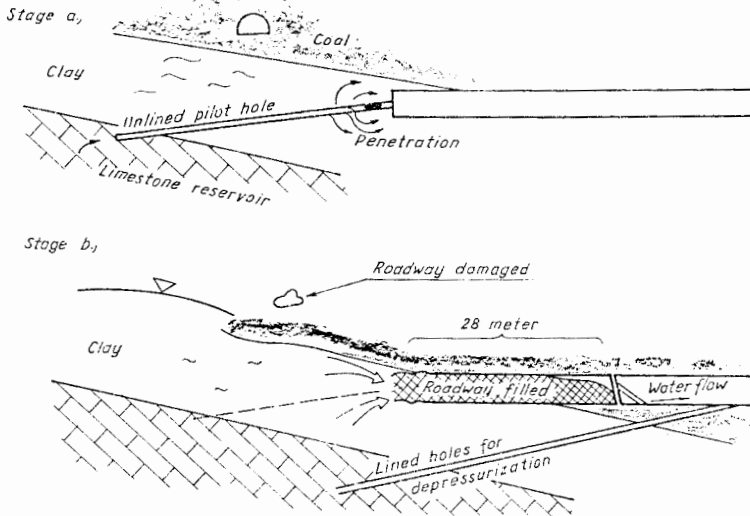

Fig. 7 Case „D“

rushes occurred in the second, third, fourth slices, in those areas, where formerly water inflows or wet rock material intrushes had been occurred or wet zones had been detected by pilot holes. After draining the limestone reservoirs, the origins of water inflows have been water accumulations in abandoned zones and at the boundary of the limestone and clay formation.

Three approximate laboratory tests determined the necessary preconditions of wet rock material intrushes. At that time no "in situ" measurement was available for planning control measurements, therefore oversized barriers were proposed first for protecting mining operations against wet rock material intrushes from zones of existing danger and from penetration new zones. Pilot holes were also proposed for checking zones of potential danger. For determining more reliable sizes of lateral and roof protective barriers detailed investigations are required according to Chapter 5. Presently the realization of the proposed investigations /in situ measurements, laboratory tests, equivalent model studies, etc./ is being carried on.

Case C A brown coal colliery was impacted by small water inflows from an underlying fissured-karstified limestone formation /see schematic cross section Fig.6/a/. Because of small water accumulations at the floor of the abandoned area, the broken clay in the abandoned workings formed dangerous equilibrium state and wet rock material inflows occurred at the quasi-horizontal ventilation roadway of the mechanized longwall face. /See Fig. 6/a/ An instantaneous drainage was proposed to prevent against water inflow and the modification of the layout of development to prevent against water accumulations. Having realized the proposals no accidents, difficulties have occurred in the last two years./Fig 6/b/

Case D Roadway was approaching a limestone reservoir by using small diameter pilot holes without lining. /See Fig.7/a/ One of the unlined pilot holes touched the reservoir and provoked water inflows of cca 0,5 m³/min. A piece of rock suddenly closed the unlined hole and the water entered into the fissures of clay. After a half an hour the dead end of the working pit started to move. As a consequence of the slow, but "invincible" movement of wet rock material a roadway length of 28 m was filled one month. The mine management depressurized the limestone reservoir at the pilot hole, by applying more drainage holes and decided to extract the wet rock material from the roadway and to continue the driving.

After analysing the case we proposed not to continue any extraction and roadway driving in this area for several reasons. These were as follows:

As a result of uncontrolled water inflows and rock movements, large areas were penetrated. Any material extraction could extend the zones of dangerous equilibrium state and finally the main roadways in the vicinity of wet rock material in-

flows may be damaged. New layout of the roadway was proposed by applying lined pilot holes for protecting against the surrounding clays, against penetration. These proposals were not accepted.

Under protection of drainage the wet rock material was extracted from the roadway without any accidents, although the volume of extracted material was much more than the volume of the filled part of the roadway. The material extraction strongly damaged the main roadways laying over. Finally the roadway driving could not be continued and a new roadway was driven successfully under protection of lined pilot holes. This case represents a combined way of forming the state of "undrained pressure". First the high pressure of penetrating water damaged the rock equilibrium. Later the wet rock movements extended the zones of increased rock pressure forming extended zones of undrained pressure as well.

CONCLUSION

The hazard of wet rock material movements should be carefully considered/analysed in all cases, when fissured or broken clay/marl is penetrated by water may occur at the surrounding area of mining operations. The methodology proposed and the case histories presented could help for predicting these phenomena and for selecting the proper control measures to protect human life and mining operations.

References

- Kassai, F. /1975/ Werkzeug und Technologie zum Schüfen des unterbauten Deckgebirges mit Kernbohrung durch die friste Unterlage bei dem Velenjeer Lignitgrube /Project report No.13-7/75 of Mining Research Institute of Hungary/
- Kézdi, A. /1972/ Soil Mechanics /Springer Berlin/
- Kesserü, Zs. Neue untersuchungen und Beobachtungen über die Schutzschichten. 7th Conference on Mine Water Management Vol.II-6 Mining Research Institute, Budapest /1976/
- Kesserü, Zs. /1976/ Untersuchungen über die Velenjeer hangendseitige Schutzschichten /Project report of the Mining Research Institute of Hungary/
- Kesserü, Zs. Water Barrier Pillars, Proceedings of the 1st IMWA Mine Water Congress, Budapest, Vol.B.p.91-117 /1982/
- Kesserü, Zs. /1978/ "Methodology and application of analyzing the rock water interaction endangering mines", Proceedings of the Conf. on Water in Mining, University of Granada, Granada, Spain, pp.637-656
- Kesserü, Zs. /1984/ Empirical and theoretical methods for designing soft semi impermeable protective barriers. /Int. Journ. of mine Water Vol.3/2/ 1984 -1-12

Kesserü, Zs. - Havasy, I. - Schmieder, A. /1978/
Proposals on control measures against water hazard for
Mine Várpalota /Project rep. of the Mining Research Inst.
of Hungary/

Kesserü, Zs. and Havasy, I. The roof-water danger at
Mine Krasnik /Yugoslavia/ and proposals on prevention and
further investigations. Project report /in English/ of
the Central Institute for Mining Development, Hungary
for Revirski Energetski Kombinat Trbovlje, Yugoslavia
/1984/

Roller, B. and Cserhalmi, I., et al. Project reports on
finite element modelling of undermined area. Technical
University of Budapest /1976/

Whittaker, B.N. - Shing, R.N. - Neate, C.J.
Influence of proximity of longwall mining on ground
permeability and subsurface drainage /1st International
Mine Drainage Symp. Denver 1979/

Whittaker, B.N. - Aston, T.R.C. Subsidence effects in
the undersea coalfield workings.